

specifications

Pressure Gauge Assembly for the medical gas alarm system shall incorporate a U.L. Listed single pole double throw snap-action micro switch. The pressure switch shall be prewired with six color coded leads. Normally open or normally closed circuitry shall be field-selected to be compatible with the medical gas alarm system design. Electrical rating shall be 10 amperes at 120 volt AC.

The pressure switch shall be tested at 160 psi with an adjustable range of .5 to 80 psi and have external calibration dials with tamper-proof cover. Factory settings shall be 40 psi and 60 psi for pressure gases.

The switch enclosure shall be a Nema 4 water tight housing with mounting bracket, 1/4" FNPT bottom inlet gas service line connection, and 3/4" FNPT top inlet conduit.

A gauge shall be incorporated after the pressure switch. A gas specific DISS nut and nipple shall be attached to the bottom of the gauge.

The Pressure Gauge Assembly will then be mounted directly to a gas specific DISS demand check (provided by Amico) directly onto the pipeline. The demand check shall have a 1/4" Male NPT connection.



features

- Removable copper diaphragm capsule
- Instrument quality snap-action switch
- Normally open or normally closed contacts
- Nema 4 water-tight housing with mounting brackets
- Pressure switches for normal 50 psig systems
- Pressure gauge with 2" dial
- DISS gas specific nut, nipple and demand check

project

switch adjustment

Pressure

Turn self locking adjustment screw counter - clockwise to increase pressure setting (all dials calibrated for increasing settings).

Inch
[mm]

Six Leads
18" Long (Approx.)

3/4" NPT Conduit
Connection

Circuit No. 1
Calibrated Dial

Circuit No. 2
Calibrated Dial

9/32" x 5/8"
Mounting
Hole (Typ.)

1/4" NPT
Gas Service
Connection

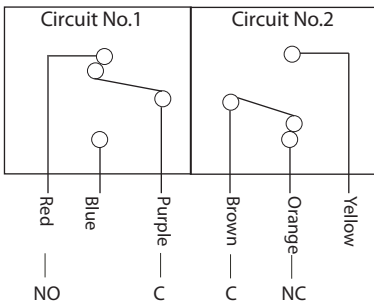
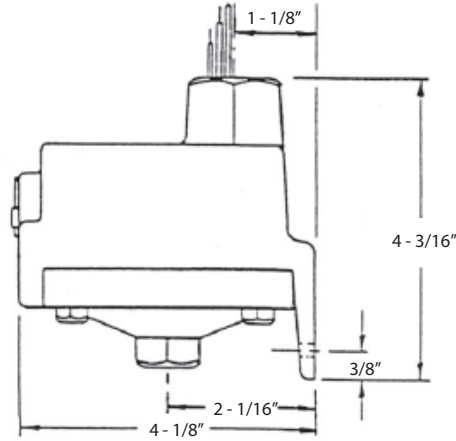
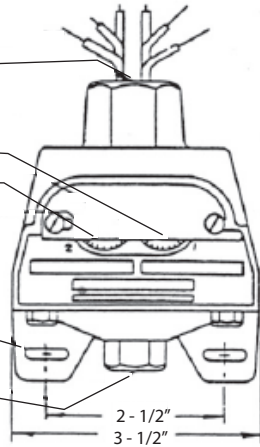

wire coding

Wiring Coding Pressure

Switch Circuit #1 Low
Common - Purple
Normally Closed - Blue
Normally Open - Red

Circuit #2 High
Common - Brown
Normally Closed - Orange
Normally Open - Yellow

model numbers

- M-PRSW-GA-OXY** = Pressure Gauge Assembly - Oxygen
- M-PRSW-GA-AIR** = Pressure Gauge Assembly - Medical Air
- M-PRSW-GA-N2O** = Pressure Gauge Assembly - Nitrous Oxide
- M-PRSW-GA-CO2** = Pressure Gauge Assembly - Carbon Dioxide

(Available for gases that have a range of 50 psi service)

represented by:

Oxygen Systems Plus, Inc.
1-800-480-7664